

Examples of cost-saving and improvement solutions in oxygen steelmaking

# Small Steps, Major Improvements\$

In addition to its well-known reputation as a complete supplier of LD (BOF) steelmaking plants, Siemens VAI also offers a wide range of systems, solutions and technological packages that help steelmakers optimize production and save costs. A few examples are outlined in the following.

**W**ith relatively simple measures and steps typically involving only smaller investments, it is possible for steelmakers to optimize production operations, increase operational reliability and enhance personnel safety. This is achieved with new design solutions, mechanical improvements and process-control enhancements. On the basis of its formidable experience in the supply of oxygen steelmaking plants, Siemens VAI helps producers achieve the full potential of their plant. As the saying goes, "There's always room for improvement."

## Converter replacements to increase production

As an example of a steelmaking project to expand output, the LD Steelmaking Plant No. 3 at voestalpine Stahl in Linz is being revamped to enable more than six million tons of steel to be produced per year, compared with the previous figure of 5.5 million t/a. All replacement and modification work has to be carried out during ongoing production, within an extremely tight time sched-

ule and under especially cramped conditions. The three 160-ton LD vessels were replaced with 180-ton vessels, and new trunnion rings with tilting drives were installed. A highly compact suspension system was designed on the basis of the well-known Vaicon Link suspension system to provide optimum converter support despite tight space conditions. New moveable skirts and offgas cooling-stack hoods will be supplied, in addition to new doghouses and alloy-charging systems for tapping. Unique was the work involving the cutting of the upper part of the three converter foundations by means of diamond-rope saws, followed by rebuilding according to the new load and anchoring requirements. The start-up of the third replaced vessel is currently scheduled for November 2009, which will also mark the successful conclusion of this project.

## Charge-mix optimization

State-of-the-art automation solutions for oxygen steelmaking are offered by Siemens VAI under the name of

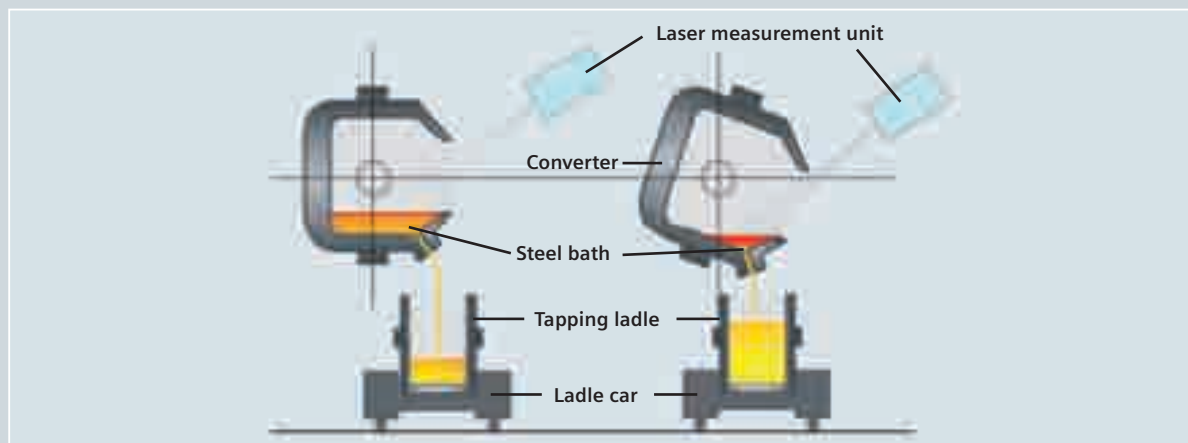

Laser-based monitoring of automatic tapping sequence

Simetal<sup>CIS</sup> BOF Optimization to maximize plant performance and product quality throughout the entire steel plant. The SteelExpert system, for example, is a group of advanced Level 2 process models that monitor and control all process steps starting with the scrap order up until alloying during tapping. The purpose of this model package is to calculate the quantity of charging materials and the required volume of oxygen to be blown in order to produce a heat according to the production schedule and required steel grade.

The SteelExpert FCC (first charge calculation) determines an optimized mix of charging materials and performs a complete precalculation of the heat. Different raw-material strategies related to the hot-metal/scrap ratio can be defined by these Level 2 system models. An optimized scrap mix of different scrap classes can be calculated on the basis of the hot-metal data and the target analysis of the heat. Depending on the actual hot metal or scrap availability and with consideration to fluctuating scrap prices, the model is also able to calculate an optimized charge mix that meets production requirements while saving costs.

Recent implementation of the SteelExpert FCC at the steel plant of Salzgitter Flachstahl GmbH in Germany demonstrated the cost-saving potential of this automation system within only a short time.

### Automatic tapping control

The basic set-up of an automatic tapping system consists of a tilting-drive position-detection and -control system, a slag-carry-over detection system and a tapping-ladle-car position-control system. For safety reasons, an infrared camera is usually installed to monitor the converter mouth area. If steel spills out of the converter mouth, the automatic tapping sequence is immediately interrupted and the converter is tilted back several degrees to prevent further steel overflow.

With the automatic tapping system from Siemens VAI, the converter is tilted to the initial tapping angle to start the procedure. The tilting-drive angle is automatically changed by the PLC-based automation system applying three different approaches: The time-based method uses a predetermined start-of-tapping angle and changes the tilting angle as a function of time. If the tapped steel weight is measured by a weighing system on the tapping car, the tilting angle can be automatically changed on the basis of this parameter. These methods do have disadvantages, however, such as the influence of the actual geometry of the tapping hole on the tapping duration and the availability of the weighing system. Siemens VAI is currently investigating a totally new method that will employ a laser-based bath-level detection system (see Figure). The steel bath level is adjusted so that it is



Fully optimized tapping control of LD (BOF) converters

close to the converter mouth with a predefined safety level to avoid possible spillage. It automatically and (nearly) continuously modifies the converter tilting angle to assure a smooth and safe tapping procedure.

### Automatic media-coupling systems

A number of quick-exchange solutions have been developed for various mechanical components, including couplings for blowing lances, sublances, and the complete media supply of exchange converters and ladles. These systems are designed to avoid any manual work for the opening or connecting of the piping with the media supply. With little modification, the quick-exchange mechanisms can be quickly installed within existing equipment facilities. For example, the Vaicon Quick Lance is a self-coupling and self-centering system. Exchange times can be reduced to approximately 15 minutes and with a minimum of manual work. Furthermore, coupling of the media piping of an exchangeable converter with the trunnion ring, or the ladle with the ladle car, is done quickly and automatically carried out with the Vaicon Joint system. This is especially important when the ladle is to be connected and disconnected often. These are important aspects for increased personnel safety and operational efficiency. ■

#### Authors

Rudolf Hubmer, Helmut Lechner, Krzysztof Pastucha

#### Contact

convertersteelmaking.metals@siemens.com